

EXPRES CUT CB70

CE EN60974-7



CODE	↔		
PAE106M-060-WA3	6 m	19.7'	1/8 GAS
PAE106M-001-WA3	6 m	19.7'	CENTRAL 001

TECHNICAL DATA		
HF	EXPRES CUT CB70	
1 m	0,6 kg	1,32 lb
V PEAK	500	
	5 bar	
	170 l/min	
X 60%	70 A	
X 100%	50 A	
	18-24mm	23/32" - 15/16"

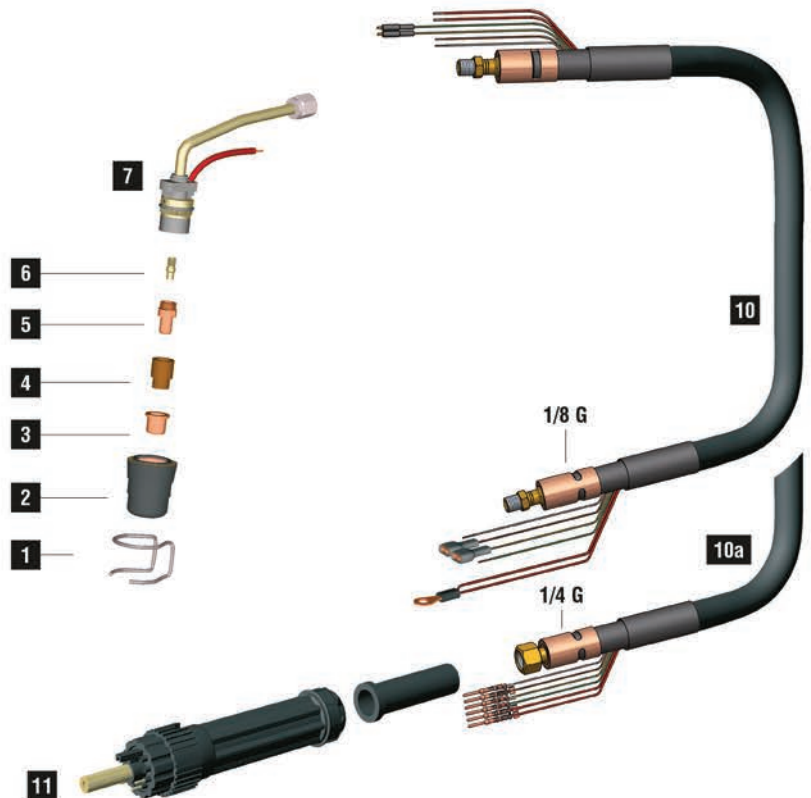
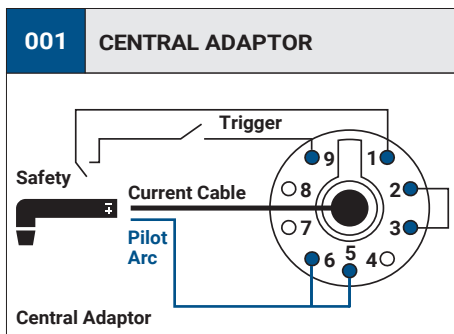

	CODE		Ø		CONTACT		DRAG		GOUGING	REF	
1	CV0010				18,5 mm					743.0149 0618, 0408-2053	10
1	CV0073		24,2 mm		31 mm						1
1	CV1117				26 mm					1405	2
2	PC0032				31,5 mm					5710171	2
3	PD0063-10		50 A	1,0 mm .040"	26,8 mm						10
3	PD0063-11		60 A	1,1 mm .043"	26,8 mm						10
3	PD0063-12		70 A	1,2 mm .047"	26,8 mm						10
3	PD0085-98		50 A	0,98 mm .038"	26,2 mm					1366	10
3	PD0088-06		20 A	0,65 mm .025"	12,3 mm						10
3	PD0088-08		40 A	0,8 mm .030"	12,3 mm						10
3	PD0088-10		50 A	1,0 mm .040"	12,3 mm					1396	10
3	PD0088-11		60 A	1,1 mm .043"	12,3 mm						10
3	PD0088-12		70 A	1,2 mm .047"	12,3 mm						1308
4	PE0007				15,6 mm					20101	2
5	CV0081										1
5	PR0063				17,8 mm					1402	10
5	PR0064				34,8 mm					1403	10
6	FH0211				12 mm						1
6	FH0215				20,5 mm						1

	CODE		
7	EA0201		O-ring 10
7	PF0065		CB70 torch head 1
8	TP0310		trigger kit 1
9	TP0302		handle kit 1
9	BW0424		spring joint 1

	CODE		
10	PH4007		coaxial cable - 6 m / 19.7' 1/8 G 1
10a	PH4001		coaxial cable - 6 m / 19.7' 1/4 G 1
11	BW0147		cable support 10
11	FY0014		plasma central adaptor - 5 pins 1
	EA0254		pin extractor for central adaptor 1
	PT0202		male spring pins kit (5 pcs) 1

STANDARD



CONTACT SHORT



CONTACT LONG



DRAG SHORT



DRAG LONG



GOUGING