

# EXPRES CUT S65

CE EN60974-7



CONTACT Consumables	↔		
PAS406M-000-WA3	6 m	19.7'	1/4 GAS
PAS406M-004-WA3	6 m	19.7'	CENTRAL 004
PAS406M-304-WA3	6 m	19.7'	TRAFIMECTOR® 304

TECHNICAL DATA		
NO HF	EXPRES CUT S65	
1 m	0,4 kg	0,88 lb
V PEAK	500	
	4 bar	
	100 l/min	
X 60%	60 A	
	16-20 mm	5/8" - 25/32"

DRAG Consumables	↔		
PAS406D-000-WA3	6 m	19.7'	1/4 GAS
PAS406D-004-WA3	6 m	19.7'	CENTRAL 004
PAS406D-304-WA3	6 m	19.7'	TRAFIMECTOR® 304

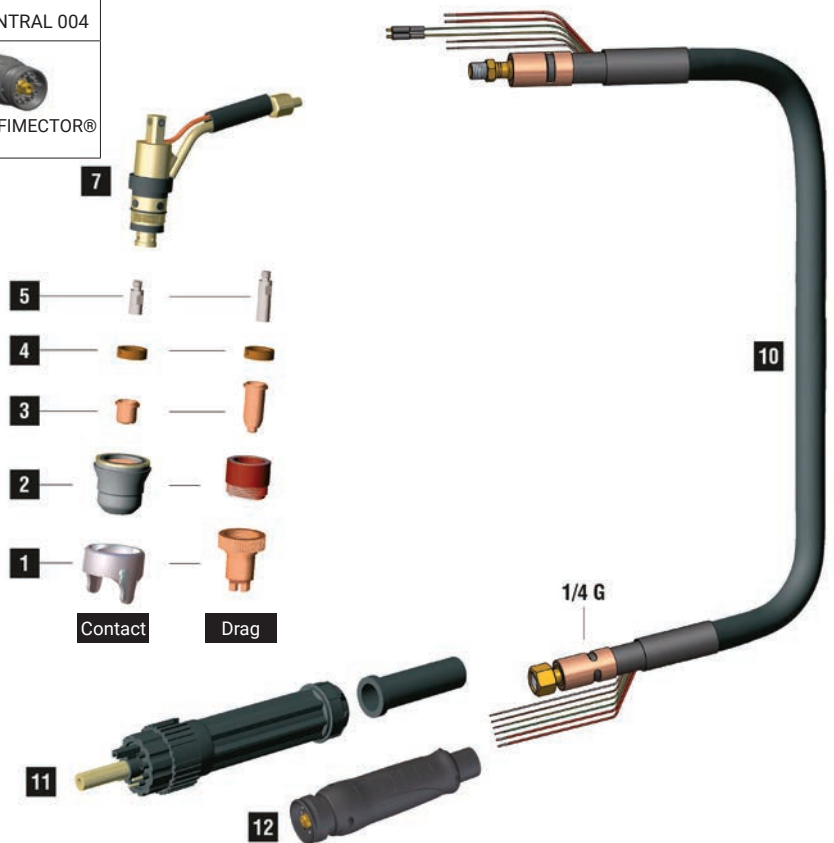
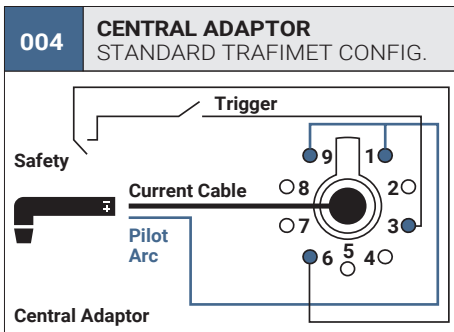

**CONSUMABLES FOR CUTTING (CONTACT)**

	CODE		Description	Ø		↔		CONTACT		DRAG		GOUGING	REF	
1	CV0299		gouging shield			20,8 mm						•		2
1	CV1118		stand off guide			25,5 mm		•						2
2	PC0098		nozzle			29 mm		•						2
2	PC0198		long life nozzle			29 mm						•		2
3	PD0098-08		40 A	0,8 mm	.030"	17,7 mm		•						10
3	PD0098-10		60 A	1,0 mm	.040"	17,7 mm		•						10
3	PD0199-16		gouging tip	1,6 mm	.063"	17,7 mm						•		10
4	PE0106		Swirl ring			4,6 mm		•				•	60028	2
5	PR0098		electrode			24,8 mm		•				•		10

**CONSUMABLES FOR DRAG**

	CODE		Description	Ø		↔		CONTACT		DRAG		GOUGING	REF	
1	CV0298		stand off guide			37,9 mm					•			2
2	PC0198		long life nozzle			29 mm					•			2
3	PD0198-08		40 A	0,8 mm	.030"	18 mm					•			10
3	PD0198-10		60 A	1,0 mm	.040"	18 mm					•			10
4	PE0106		Swirl ring			4,6 mm					•		60028	2
5	PR0106		electrode			30,5 mm					•			10

	CODE		Description	
7	EA0330		o-ring	10
7	PF0128		S65 torch head	1
8	TP0310		trigger kit	1
9	TP0301		handle kit	1
9	BW0424		spring joint	10

	CODE		Description	
10	PH4027		coaxial cable - 6 m / 19.7' - 1/4 G (no pin)	1
11	BW0147		cable support	10
11	FY0023		plasma central adaptor - 5 pins	1
12	FY0090		TRAFIMECTOR® central adaptor - torch side	1
	EA0254		pin extractor for central adaptor	1
	PT0202		male spring pins kit (5 pcs)	1

STANDARD



CONTACT SHORT



CONTACT LONG



DRAG SHORT



DRAG LONG



GOUGING