

# EXPRES CUT S105

CE EN60974-7



CODE	↔		
PAS606M-000-WA3	6 m	19.7'	 1/4 GAS
PAS606M-004-WA3	6 m	19.7'	 CENTRAL 004
PAS606M-304-WA3	6 m	19.7'	 TRAFIMECTOR® 304

TECHNICAL DATA		
<b>NO HF</b>	EXPRES CUT S105	
	0,7 kg	1,54 lb
<b>V PEAK</b>	500	
	5 bar	
	180 l/min	
<b>X 60%</b>	100 A	
<b>X 100%</b>	70 A	
	25-30mm	1"-1 3/16

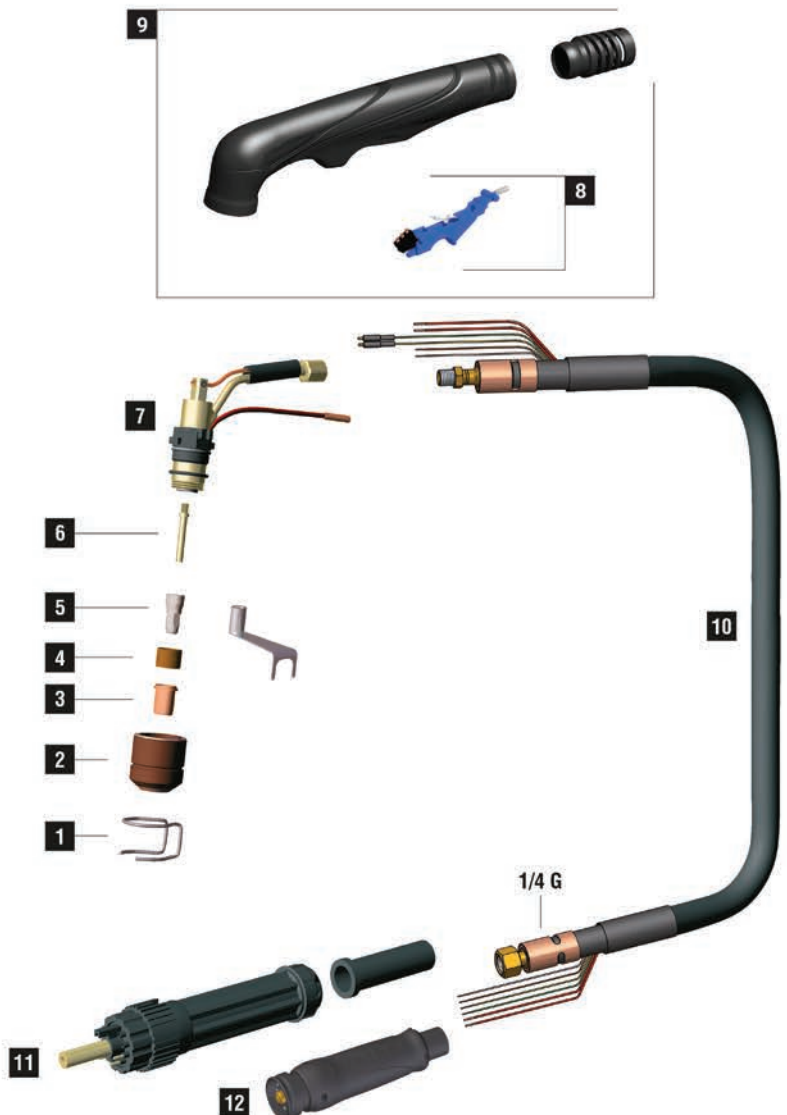
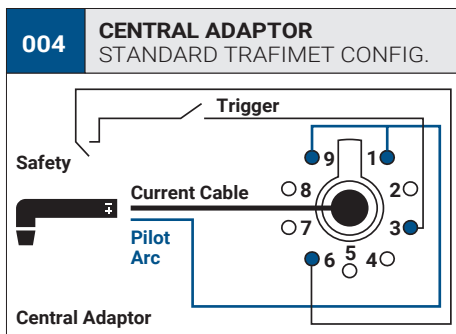

	CODE		Description	Ø			CONTACT		DRAG		GOUGING	REF	
1	CV0009		stand off guide			38,6 mm							10
1	CV0011		stand off guide			23 mm						1386	10
1	CV0012		stand off guide			30 mm						1408	2
1	CV0014		stand off guide			30 mm							2
1	CV0021		stand off guide	32,8 mm		40,6 mm							1
2	PC0118		long life nozzle			39,5 mm							4
2	PC0119		long life nozzle			32 mm							2
3	PD0119-10		50 A	1,0 mm	.040"	18,7 mm							10
3	PD0119-12		70 A	1,2 mm	.047"	18,7 mm							10
3	PD0119-14		100 A	1,4 mm	.055"	18,7 mm							10
3	PD0122-12		70 A	1,2 mm	.047"	34,3 mm							10
4	PE0112		diffuser			11,5 mm							2
5	CV0080		tool for wear parts										1
5	PR0117		electrode			23,7 mm							10
5	PR0120		electrode			39,5 mm							10
6	FH0647		air tube			36 mm							10
6	FH0820		long air tube			50 mm							10

	CODE		Description	
7	EA0223		O-ring Ø 18x1 mm	10
7	PF0136		S105 torch head	1
8	TP0310		trigger kit	1
9	TP0303		handle kit	1
9	BW0424		spring joint	1

	CODE		Description	
10	PH4003		coaxial cable - 6 m / 19.7' - 1/4 G (no pin)	1
11	BW0147		cable support	10
11	FY0023		plasma central adaptor - 5 pins	1
12	FY0090		TRAFIMECTOR® central adaptor - torch side	1
	EA0254		pin extractor for central adaptor	1
	PT0202		male spring pins kit (5 pcs)	1

STANDARD



CONTACT SHORT



CONTACT LONG



DRAG SHORT



DRAG LONG



GOUGING